

SL 5500/6500/8500 Series

HORIZONTAL TURNING CENTER



SMEC Co., Ltd.

157-10, Goldenroot-ro, Juchon-myeon, Gimhae-si,
Gyeongsangnam-do, Korea

Tel +82 55 340 4800 / Fax +82 55 340 4740

www.smecmachinetools.com



SL 5500/6500/8500 Series

- SL 5500/6500/8500
- SL 6500X/8500X
- SL 6500L/8500L
- SL 6500XL/8500XL
- SL 5500M/6500M/8500M
- SL 6500XM/8500XM
- SL 6500LM/8500LM
- SL 6500XLM/8500XLM

SL 5500/6500/8500 Series

Heavy duty and precision machining in a compact footprint with ease of use features

- 45 degree TORQUE TUBE RIB bed to support heavy duty machining
- High precision machining possible during heavy duty cutting
- Significantly reduced non-cutting time for high efficiency machining
- Servo turret for improved high speed performance
- Low center of gravity design minimizing vibration and thermal growth for high precision turning



Superb spindle structure

The radiator fin head assembly to minimize thermal growth and Bzi sensor increases rotation accuracy for high quality machining

Optimized feed system design

The pre-tensioned double anchored feed system and 6 contact surface x-axis slideway frame enables high precision and heavy duty cutting

Category		SL 5500A/AM	SL 5500B/BM	SL 5500C/CM
Swing over bed	mm(inch)	900(35.44)	900(35.44)	900(35.44)
Max turning length	mm(inch)	1,097(43.19)/1,079(42.49)	1,097(43.19)/1,079(42.49)	1,070(43.19)/1,052(41.42)
Chuck size	inch	21"	24"	32"
Spindle bore	mm(inch)	181(7.13)	181(7.13)	275(10.83)
Spindle speed	rpm	1,500/1,200	1,500/1,200	1,000/1,000
Main Motor(cont./max)	kW(Hp)	30/45(40.24/60.35)	30/45(40.24/60.35)	37/55(49.62/73.76)
Travels X	mm(inch)	370(14.57)	370(14.57)	370(14.57)
Travels Z	mm(inch)	1,130(44.49)	1,130(44.49)	1,130(44.49)
No of tool positions	EA	12/12(BMT75)	12/12(BMT75)	12/12(BMT75)

Category		SL 6500A/AM B/BM	SL 6500AX/AXM BX/BXM	SL 6500AL/ALM BL/BLM	SL 6500AXL/AXLM BXL/BXLM
		SL 8500A/AM B/BM	SL 8500AX/AXM BX/BXM	SL 8500AL/ALM BL/BLM	SL 8500AXL/AXLM BXL/BXLM
Swing over bed	mm(inch)	1,030(40.56)	1,030(40.56)	1,030(40.56)	1,030(40.56)
Max turning length	mm(inch)	1,000(39.38)	2,000(78.75)	3,200(125.99)	5,050(198.82)
Chuck size	inch	21" 24" 32"	21" 24" 32"	21" 24" 32"	21" 24" 32"
Spindle bore	mm(inch)	152(5.99) 321(12.64)	152(5.99) 321(12.64)	152(5.99) 321(12.64)	152(5.99) 321(12.64)
Spindle speed	rpm	1,500 1,200 500	1,500 1,200 500	1,500 1,200 500	1,500 1,200 500
Main Motor(cont./max)	kW(Hp)	37/55(49.62/73.76)	37/55(49.62/73.76)	37/55(49.62/73.76)	37/55(49.62/73.76)
Travels X	mm(inch)	470(18.51)	470(18.51)	470(18.51)	470(18.51)
Travels Z	mm(inch)	1,050(41.34)	2,050(80.71)	3,270(128.75)	5,100(200.79)
No of tool positions	EA	12/12(BMT85)	12/12(BMT85)	12/12(BMT85)	12/12(BMT85)

High rigidity design

The 45-degree slanted bed with torque tube ribbed structure suppresses vibration during heavy duty cutting for high precision machining

Operator centered convenience features

Operator convenience maximized with features such as M-CODE based programmable tailstock, Manual Guide i and operator centered panel

SL 5500/6500/8500 Series

HORIZONTAL TURNING CENTER

Superior spindle design



Radiator fin head assembly to minimize thermal growth

The radiator fin like ribbed structure of the head assembly minimizes thermal growth for precision machining



Reduced service issues with new spindle orientation sensor design

Spindle orientation sensor changed from position encoder to Bzi sensor, removing the need to adjust the timing belt and improving rotation accuracy and increasing productivity by removing a point of maintenance

High rigidity design



High rigidity 45-degree slant bed to support heavy-duty cutting

The 45-degree slant bed with torque tube rib structure offers superb twisting and bending resistance during heavy duty cutting, enabling high precision machining.

Also, the slant bed allows for easier access to the workpiece and superb chip discharge

Effective chip removal

The 45° slant bed allows easy chip removal while making it easier to change tools and inspect parts

Optimize travel system

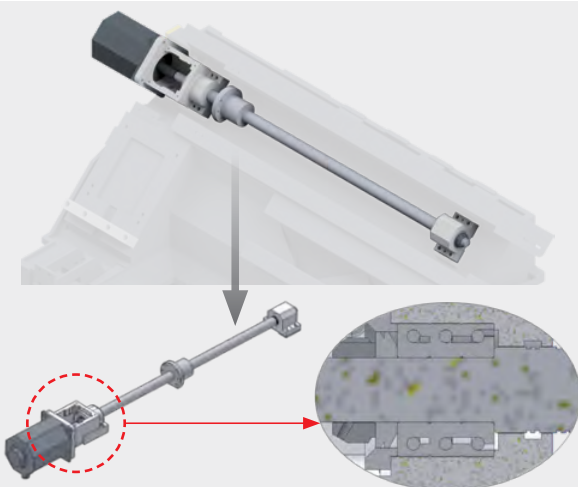

Pre-tensioned double anchored travel axis

All travel axes employ pre-tensioned double anchored ball screws to minimize thermal growth and are supported on both ends using high precision P4 angular bearings for high precision operation

- Pre-tensioned double anchored (minimize thermal growth)
- High precision angular bearing+large diameter high precision ball screws

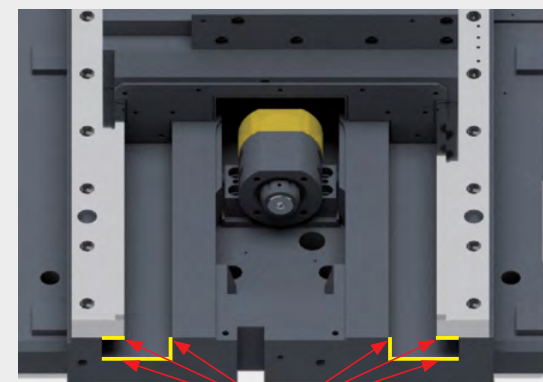

Hexahedral Slide Way Frame

6 contact surface slideway frame (X-axis)

The wide guideway surfaces and contact surface slideways are heat treated and precision ground to maintain high precision, heavy duty cutting capability over its lifetime

User-centric options and convenience features

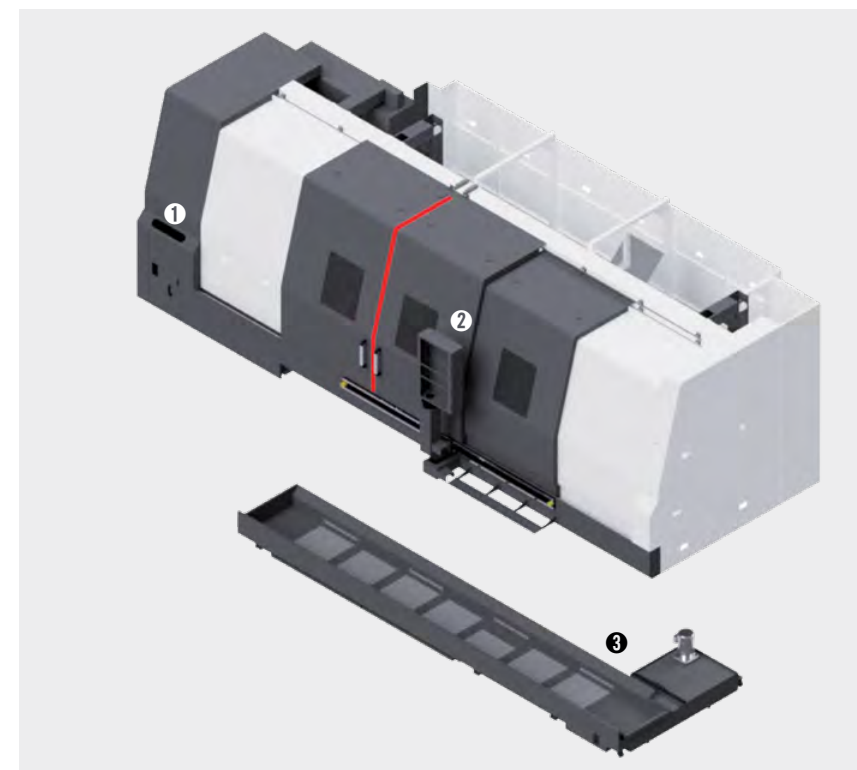

1 Easy hydraulic valve adjustment

The gauge and hydraulic valves are located at a height that make it easy for the operator to adjust

2 User-centric Large 15" OP Panel

The QWERTY-type keyboard and high visibility buttons and effective button placement enhances ease of use

3 Easy coolant tank maintenance

When cleaning the coolant tank, the coolant tank may be removed while leaving the chip conveyor attached to the machine, making it easier to clean and maintain

SL 5500/6500/8500 Series

HORIZONTAL TURNING CENTER

Machine Design

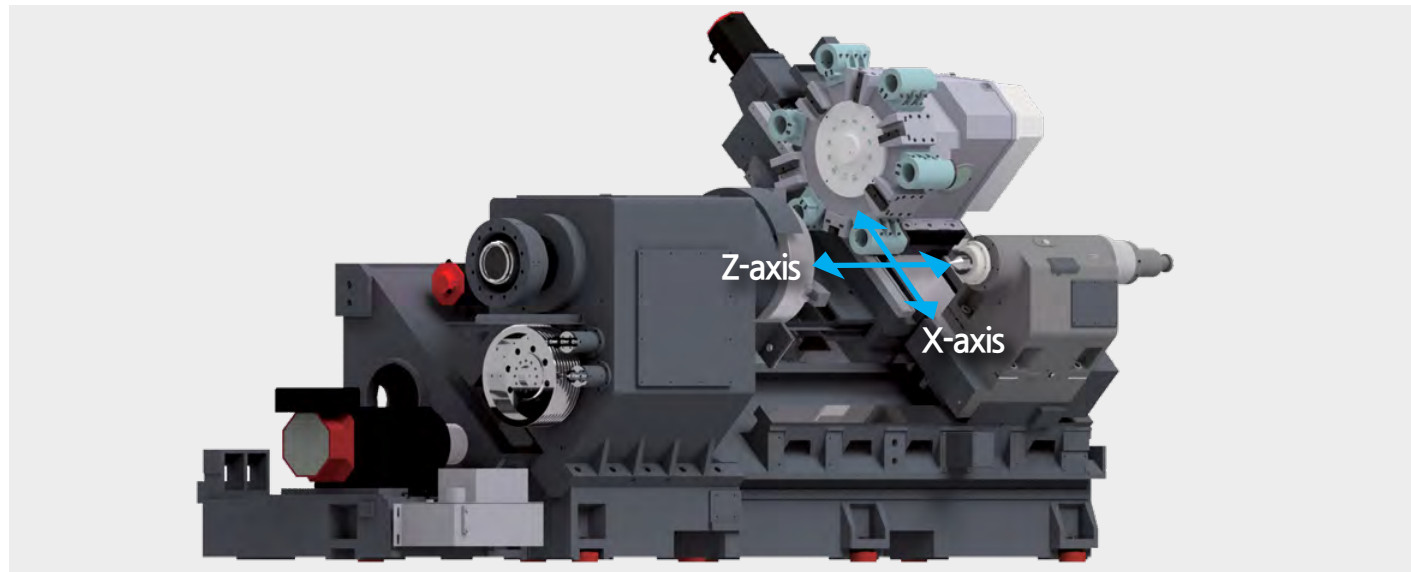

Model	Travel [mm (inch)]		Rapid traverse [m/min (ipm)]	
	X-axis	Z-axis	X-axis	Z-axis
SL 5500/M	370(14.57)	1,130(44.49)	20(787.41)	20(787.41)
SL 6500/8500/M	470(18.51)	1,050(41.34)	12(472.45)	18(708.67)
SL 6500X/8500X/XM	470(18.51)	2,050(81.71)	12(472.45)	15(590.56)
SL 6500L/8500L/LM	470(18.51)	3,270(128.75)	12(472.45)	10(393.71)
SL 6500XL/8500XL/XLM	470(18.51)	5,100(200.79)	12(472.45)	10(393.71)

All travel axes are comprised of high rigidity box guideways enabling heavy duty cutting and superb productivity

Work Range

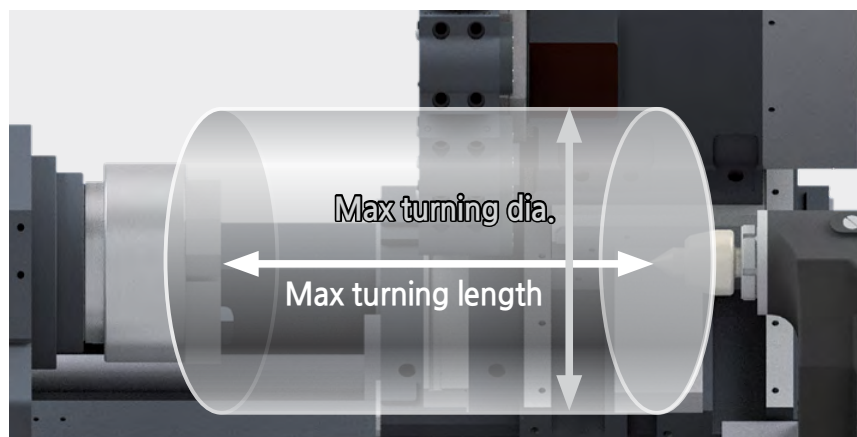

Model	Max turning dia [mm (inch)]	Max turning length [mm (inch)]
SL 5500/M	Ø690(27.17)	1,097(43.19)
SL 6500/8500/M	Ø900(35.44)	1,000(39.38)
SL 6500X/8500X/XM	Ø900(35.44)	2,000(78.75)
SL 6500L/8500L/LM	Ø900(35.44)	3,200(125.99)
SL 6500XL/8500XL/XLM	Ø900(35.44)	5,050(198.82)

Providing a large work envelope, ensuring cost effective productivity

Max turning dia/length

SL 5500/M	Ø690/1,097mm(27.17/43.19 inch)
SL 6500/8500/M	Ø900/1,000mm(35.44/39.38 inch)
SL 6500X/8500X/XM	Ø900/2,000mm(35.44/78.75 inch)
SL 6500L/8500L/LM	Ø900/3,200mm(35.44/125.99 inch)
SL 6500XL/8500XL/XLM	Ø900/5,050mm(35.44/198.82 inch)

Spindle

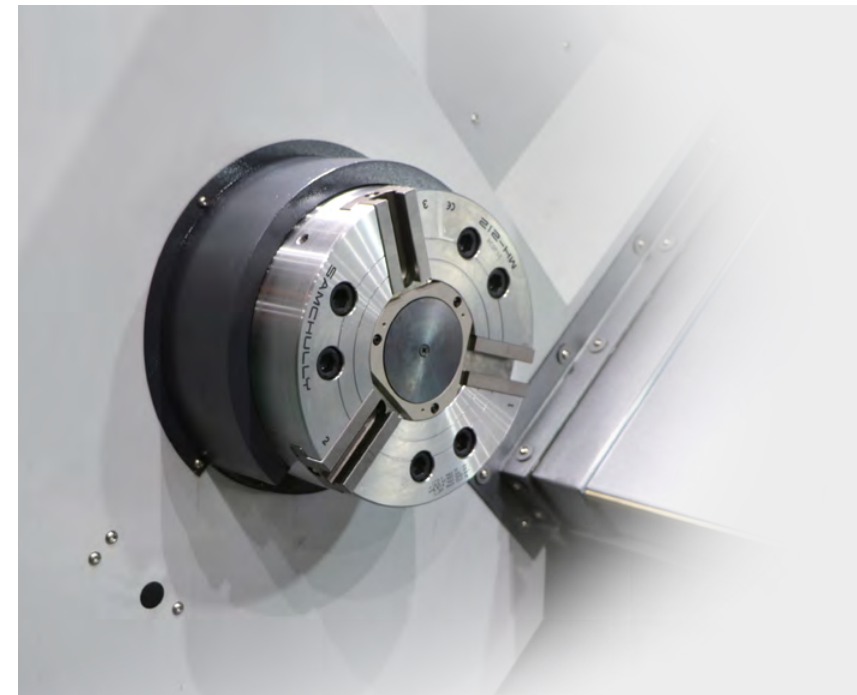

Model	Chuck size	Speed [rpm]	Power (cont/Max.) [kW (Hp)]	Torque (cont/Max.) [N·m (lbs.ft)]
SL 5500A series	21"	1,500	30/45(40.24/60.35)	2,803/4,205(2,067.39/3,101.45)
SL 5500C series	32"	1,000	37/55(49.62/73.76)	3,742/5,562(2,759.96/4,102.33)
SL 6500A series	21"	1,500	37/55(49.62/73.76)	4,520/6,719(3,333.79/4,955.69)
SL 6500B series	24"	1,200	37/55(49.62/73.76)	4,520/6,719(3,333.79/4,955.69)
SL 8500 series	32"	500	37/55(49.62/73.76)	5,441/8,088(4,013.08/5,965.41)

The high power motor allows both high precision and high torque machining, improving operator productivity.

SL 5500 Series (A Type)

Max spindle speed	Power (cont/Max.)
1,500rpm	30/45kW (40.24/60.35 Hp)
Torque (cont/Max.)	
2,803/4,205N·m (2,067.39/3,101.45 lbs.ft)	

SL 5500 Series (C Type)

Max spindle speed	Power (cont/Max.)
1,000rpm	37/55kW (49.62/73.76 Hp)
Torque (cont/Max.)	
3,742/5,562N·m (2,759.96/4,102.33 lbs.ft)	

SL 6500 Series (A/B Type)

Max spindle speed	Power (cont/Max.)
1,500/1,200rpm	37/55kW (49.62/73.76 Hp)
Torque (cont/Max.)	
4,520/6,719N·m (3,333.79/4,955.69 lbs.ft)	

SL 8500 Series

Max spindle speed	Power (cont/Max.)
500rpm	37/55kW (49.62/73.76 Hp)
Torque (cont/Max.)	
5,441/8,088N·m (4,013.08/5,965.41 lbs.ft)	

SL 6500/8500 Series_Mill Motor

Max spindle speed	Power (cont/Max.)
3,000rpm	7.5/11kW (10.06/14.76 Hp)
Torque (cont/Max.)	
95.5/140.1N·m (70.44/103.34 lbs.ft)	

The high precision Double Row of Cylindrical Roller Bearings and Angular Ball Bearings on the front end of the spindle and the Double Row of Cylindrical Roller Bearings on the back end of the spindle ensure high precision, high speed machining performance

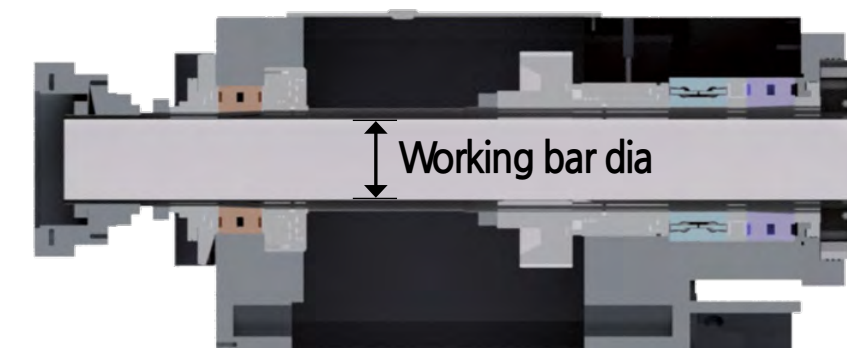

Model	Working bar dia [mm (inch)]	Spindle nose [ASA]
SL 5500A series	Ø181(7.13)	A2-15
SL 5500C series	Ø275(10.83)	A2-20
SL 6500 series	Ø152(5.99)	A2-15
SL 8500(A/B type) series	Ø321/365(12.64/14.38)	A1-20/A2-20
SL 8500M(A/B type) series	Ø321/365(12.64/14.38)	A1-20/A2-20

SL 5500/6500/8500 Series

HORIZONTAL TURNING CENTER

Turret

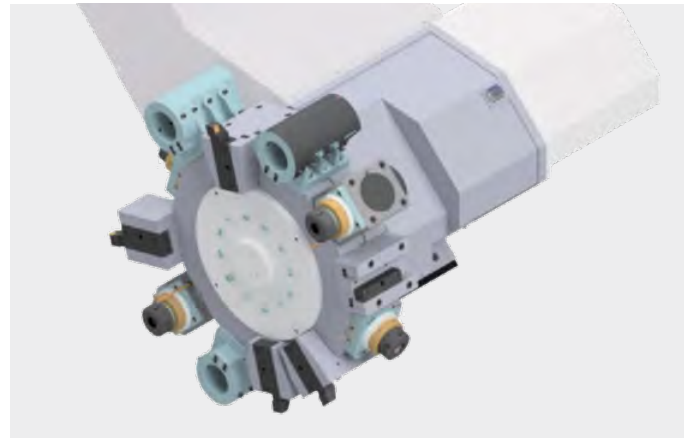
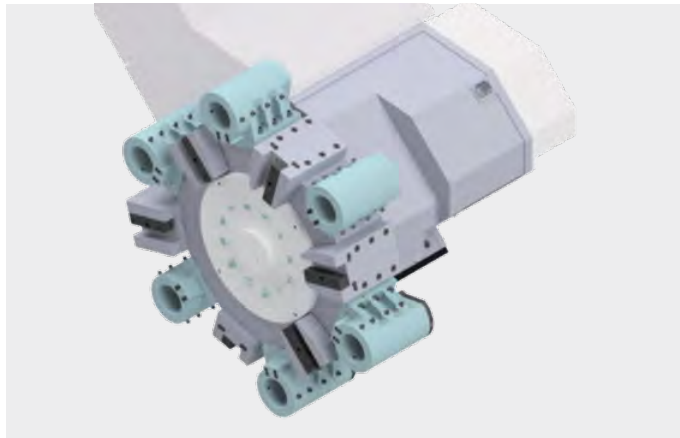

Servo turret

The turret uses a highly reliable, high-power servo motor and the Non-stop Random index method.

2-axis turret

The 0.25 second turret indexing time significantly reduces non-cutting time, while the 3 piece curvic coupling greatly enhances the clamping force and index accuracy.

Turret indexing time : **0.25sec**

No. of tool positions : **12ea** (□32×32, Ø80)
(□1.26"×1.26", Ø3.15")

BMT milling turret

This 12 station (BMT85) turret with the largest in class curvic coupling and power hydraulic clamping force is capable of accepting a rotary tool in every tool position and allows a variety of machining operations with a single set-up. The best in class BMT85 tool holders ensures high rigidity, high precision machining and with non-stop turret indexing in either direction minimizes the turret index time down to 0.25 seconds per station.

Turret indexing time : **0.25sec**

No. of tool positions : **12ea** (□32×32, Ø80)
(□1.26"×1.26", Ø3.15")

Tailstock

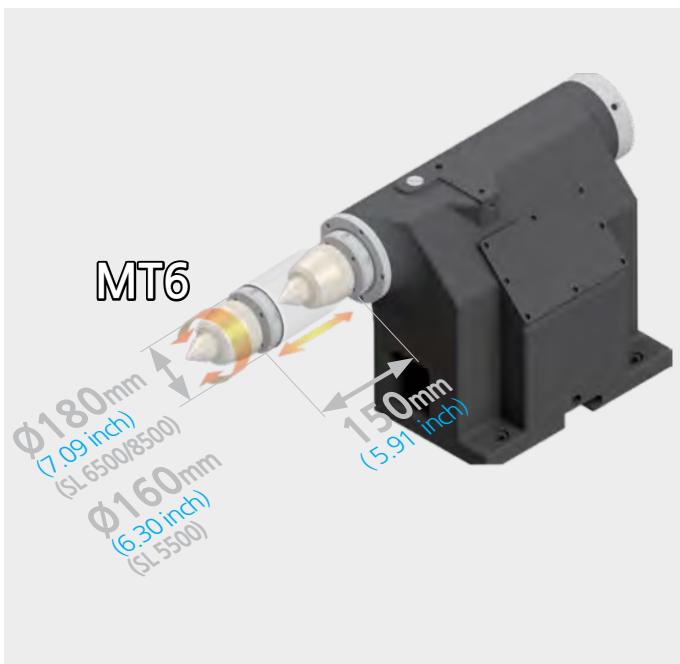

Programmable tailstock [standard]

The programmable tailstock is capable of automated forward/reverse of the tailstock and quill using M-codes and maintains high precision during heavy duty machining.

Quill stroke : **150mm(5.91 inch)**

Quill taper : **MT6**(SL 6500/8500)
MT5(SL 5500)

Accessories[Optional]

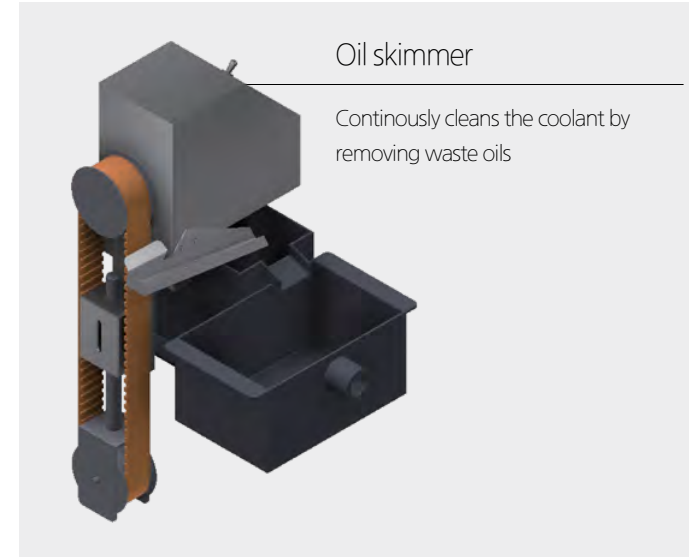

Autodoor

Used to quickly open/close the operator door via program to increase productivity in an automation line.

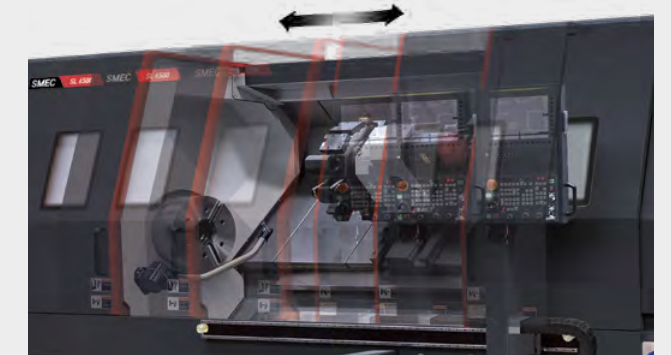

Tool presetter

Provides faster and more precise tool setup, checking for tool wear and compensation



Air blow

Used to automatically remove chips from the chuck after machining and used for safe loading of the chuck in an automated line.



Steady rest

Provides additional stability when cutting long parts and the size of the steady rest may be selected

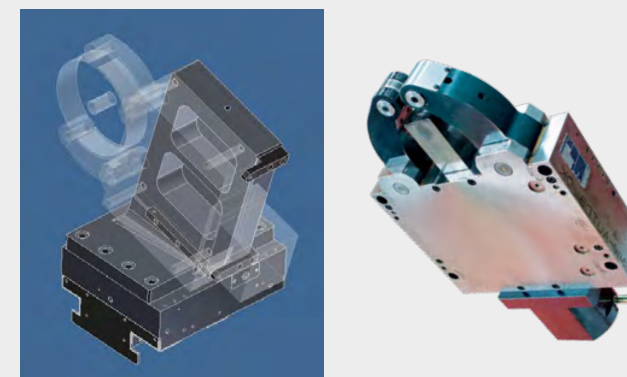

Chip conveyor

Used to discharge chips created during machining

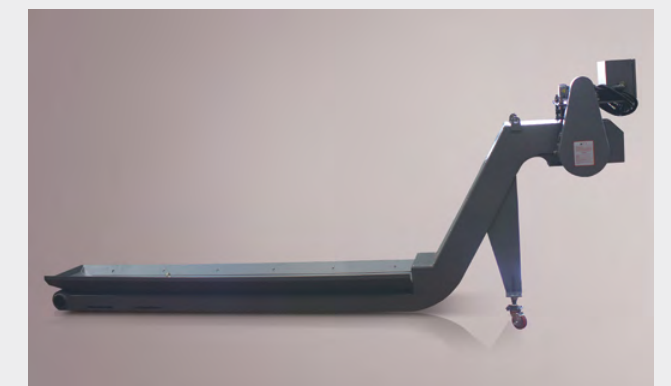

SMC FANUC i series



- 15" LCD color display
- High quality designed OP Panel
- Conversational programming, Manual Guide i
- Part program size 2MB
- SMC Custom S/W

SMC Custom S/W displayed using MDI's **S1** button or OP Panel's **CUSTOM** button

CUSTOM : Provide operator convenience and improve productivity using the support function for tool management and additional device setting.



M/G-Code check function

Allows the operator to directly read the M/G-Code on the machine for easy application programming



Easy tailstock setting

Easily configure a variety of functions such as travel limiting, origin setting and signal check



Display only the necessary tools and offsets and check the configured counter at the same time

Tool information and setting management mode

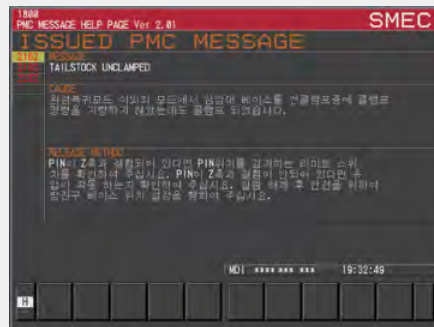

PMC alarm check function

When a PMC alarm occurs, the cause and countermeasures are described in detail, making operation and maintenance more convenient



Counter for each T-Code

Manual Guide i (STD)

SMC's Manual Guide i system enables advanced part program creation and more efficient and faster machining with conversational programming



Check cutting result using cutting simulation



Check cutting path using cutting simulation

Easy program creation and editing

Program creation using advanced part program editing and extensive cutting cycles

Check program using cutting simulations

Program pre-check using realistic cutting simulation

Effective cutting setup

Tool and cutting condition offset data setup based on measurement cycle

Advanced cutting capabilities

Check cutting status such as cutting cycle name and tool icon during the cutting process

Measurement

Feedback of cutting results and tool offset values after cutting

IoT Solution (OPT)



NC-Gate / IoT-Gate

The NC-Gate / IoT-Gate that was developed in-house with our ICT technology is a universal gateway that not only interworks with our machine tools, but machine tools from other manufacturers, robots, automation equipment, and analog / digital sensors as a network device capable of bi-directional communication.

Supported drivers : Fanuc / Mitsubishi / Siemens NC, Modbus TCP, DeviceNet, Profibus, Ethernet, AI/DI/DO



Provides key performance indicators and displays target achievement

- Indicators : achievement rate, productivity, process defect rate, equipment and factory usage, quality defect rate, lead time, and average cycle time



Provides figures and graphs of overall equipment effectiveness

- Availability, performance, quality, etc.



Provides operation status and alarm information in case of problems in the production line

- Provides information about the operation status, speed, production alarms, etc. of each machine



Remote control and operation

- Emergency stop switch, program editing, etc.

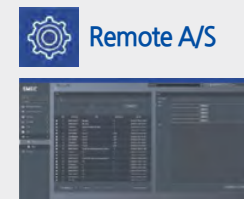

Problem diagnosis via remote control

- Provide remote diagnosis services to users via the IIoT solution

SL 5500/6500/8500 Series

HORIZONTAL TURNING CENTER

Power-Torque Diagram

SL 5500A/AM_Main Spindle

Max speed
1,500rpm

Power (cont/Max.)
30/45kW
(40.24/60.35 Hp)

Torque (cont/Max.)
2,803/4,205N·m
(2,067.39/3,101.45 lbs-ft)

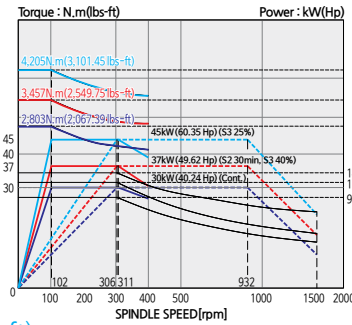

SL 5500C/CM_Main Spindle

Max speed
1,000rpm

Power (cont/Max.)
37/55kW
(49.62/73.76 Hp)

Torque (cont/Max.)
3,742/5,562N·m
(2,759.96/4,102.33 lbs-ft)

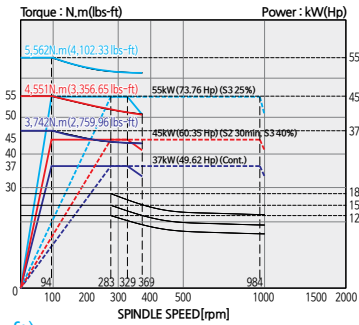

SL 6500 Series_Main Spindle

Max speed(A/B type)
1,500/1,200rpm

Power (cont/Max.)
37/55kW
(49.62/73.76 Hp)

Torque (cont/Max.)
4,520/6,719N·m
(3,333.79/4,955.69 lbs-ft)

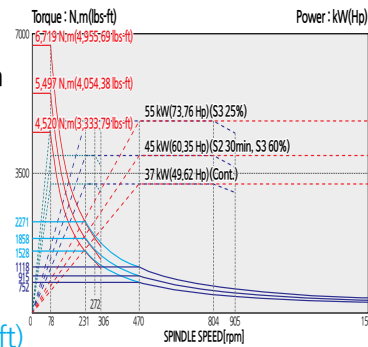

SL 8500 Series_Main Spindle(12" BORE)

Max speed
500rpm

Power (cont/Max.)
37/55kW
(49.62/73.76 Hp)

Torque (cont/Max.)
5,441/8,088N·m
(4,013.08/5,965.41 lbs-ft)

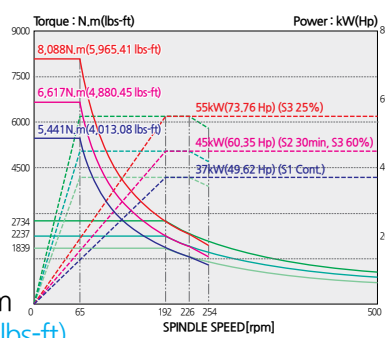

SL 8500 Series_Main Spindle(14" BORE)

Max speed
300rpm

Power (cont/Max.)
37/55kW
(49.62/73.76 Hp)

Torque (cont/Max.)
5,441/8,088N·m
(4,013.08/5,965.41 lbs-ft)

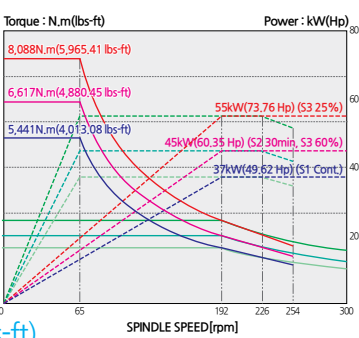

SL 6500/8500 Series_MILL Motor

Max speed
3,000rpm

Power (cont/Max.)
7.5/11 kW
(10.06/14.76 Hp)

Torque (cont/Max.)
95.5/140.1N·m
(70.44/103.34 lbs-ft)

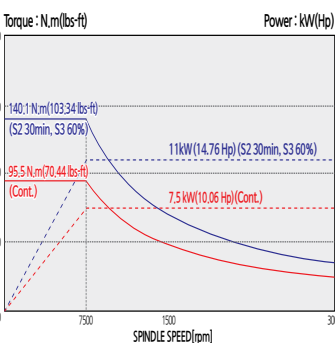

Machine Dimensions

Unit : mm(inch)

Top view

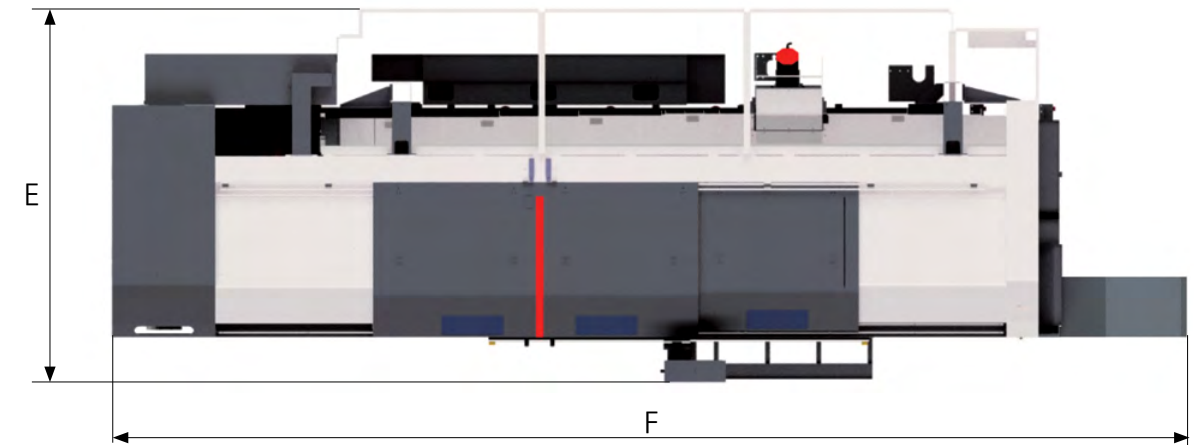

Front view

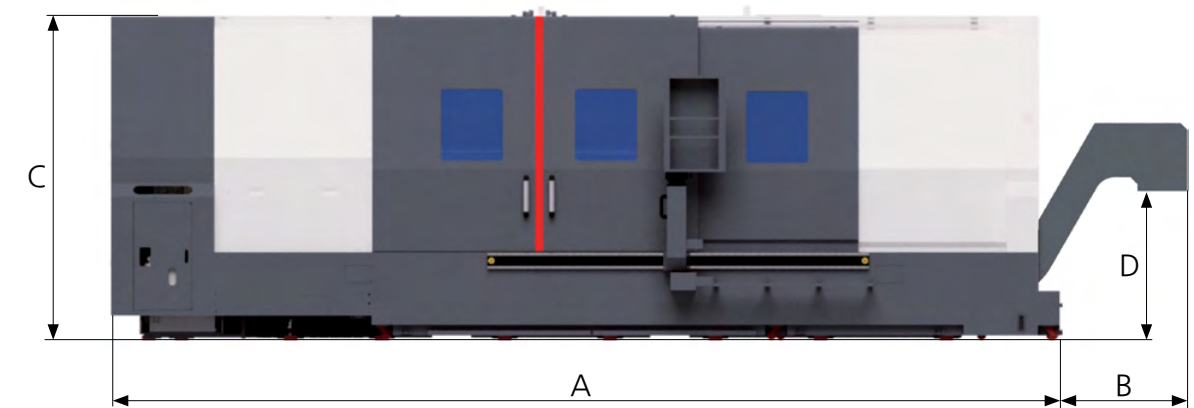

Model	A (Machine front)	B	C (Machine height)	D	E (Machine side)	F
SL 5500/M	5,159(203.12)	882(34.73)	2,344(92.29)	791(31.15)	2,100(82.68)	6,041(237.84)
SL 6500/8500/M	5,158(203.31)	1,013(39.89)	2,597(102.25)	1,106(43.55)	2,714(106.86)	6,171(242.96)
SL 6500X/8500X/XM	6,203(244.22)	1,013(39.89)	2,520(99.22)	1,106(43.55)	2,910(114.57)	7,216(284.10)
SL 6500L/8500L/LM	7,400(291.34)	1,013(39.89)	2,595(102.17)	1,106(43.55)	2,910(114.57)	8,413(331.23)
SL 6500XL/8500XL/XLM	9,281(365.40)	1,070(42.13)	2,645(104.14)	880(34.65)	2,980(117.33)	10,351(407.52)

SL 5500/6500/8500 Series

HORIZONTAL TURNING CENTER

Turret Interference

Unit : mm(inch)

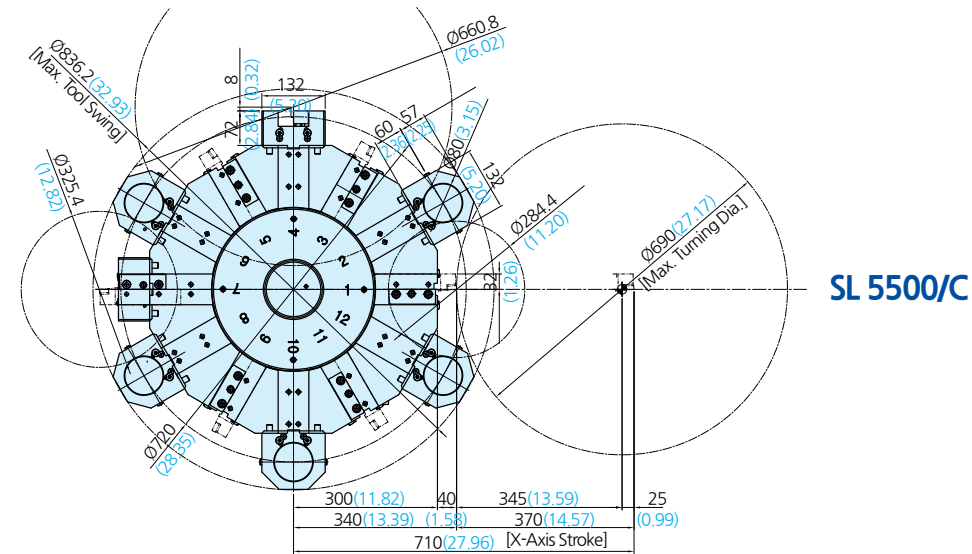

SL 5500 series(BMT 75)

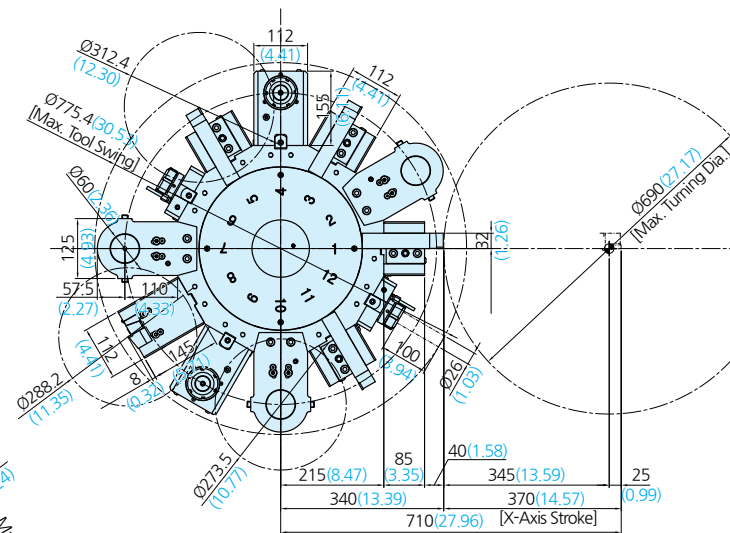

SL 5500 series(BMT 85)

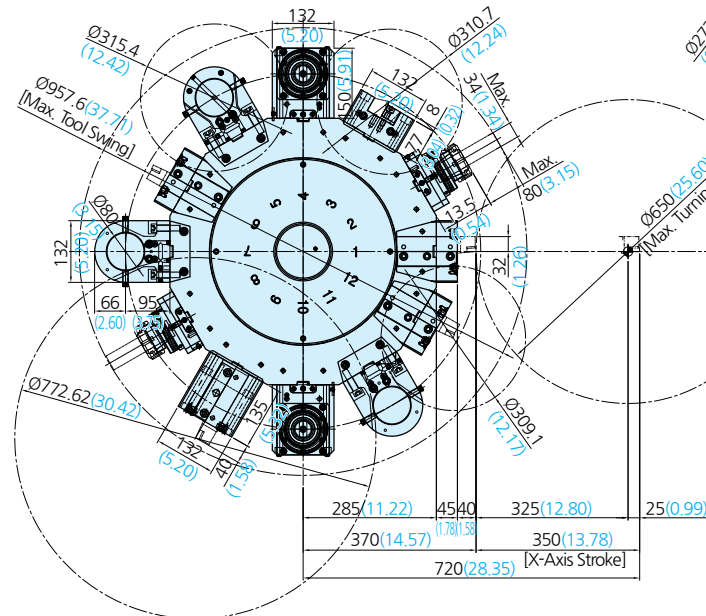

Turret Interference

Unit : mm(inch)

SL 6500/8500 series

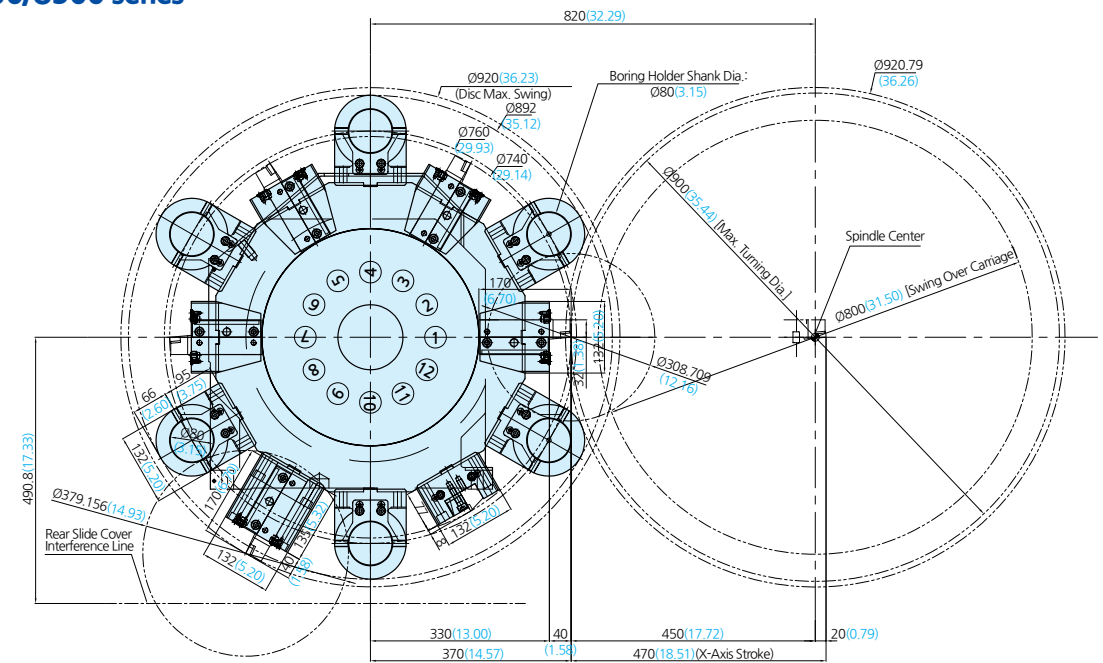

SL 6500M/8500M series

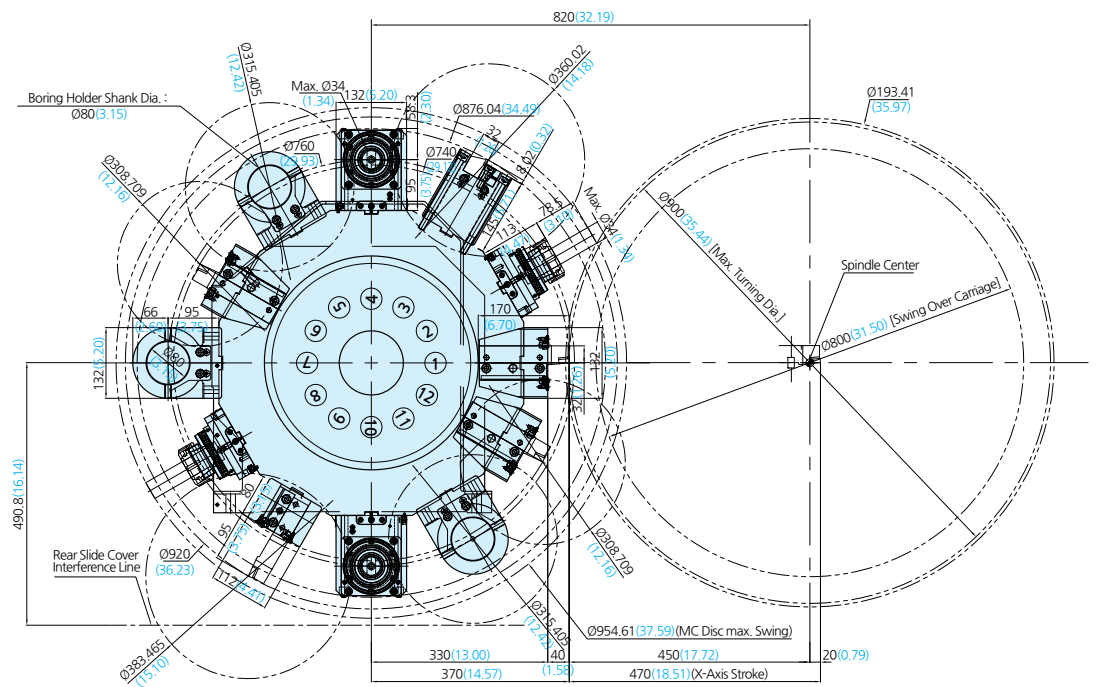

Tooling System

Unit : mm(inch)

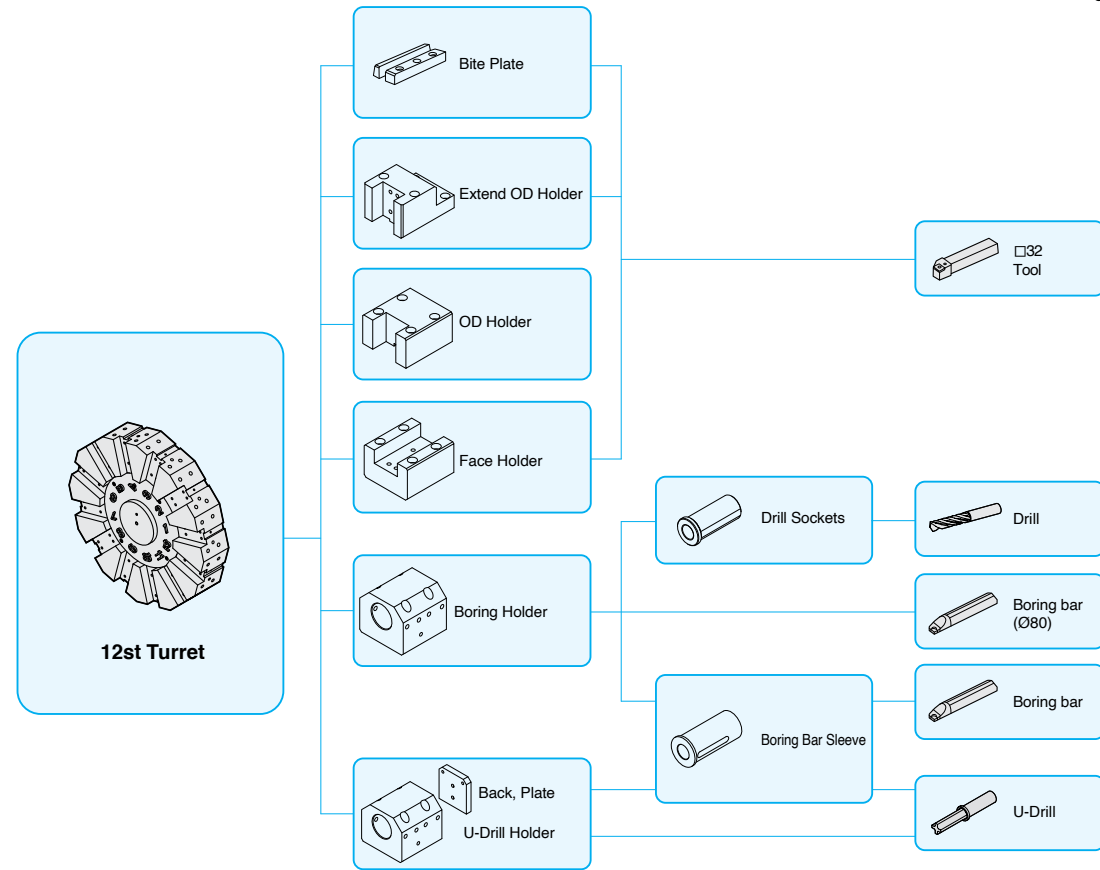

Standard Tooling

Item / Description		SL 5500 serie	SL 6500/8500 serie
Turning Holder	EXTENSION OD HOLDER	-	1
	OD HOLDER	-	4
	Facing Holder	-	1
Boring Holder	BORING HOLDER	-	4
	U-Drill Holder	-	2
Driven Holder	AXIAL DRIVEN HOLDER	-	-
	RADIAL DRIVEN HOLDER	-	-
Socket	Boring	Ø20 (Ø3/4")	1
		Ø25 (Ø1")	1
		Ø32 (Ø1 1/4")	1
		Ø40 (Ø1 1/2")	1
		Ø50 (Ø2")	1
		Ø60 (Ø2 1/2")	1
		Drill	MT 3
	MT 4		1
	MT 5		1

Tooling System

Unit : mm(inch)

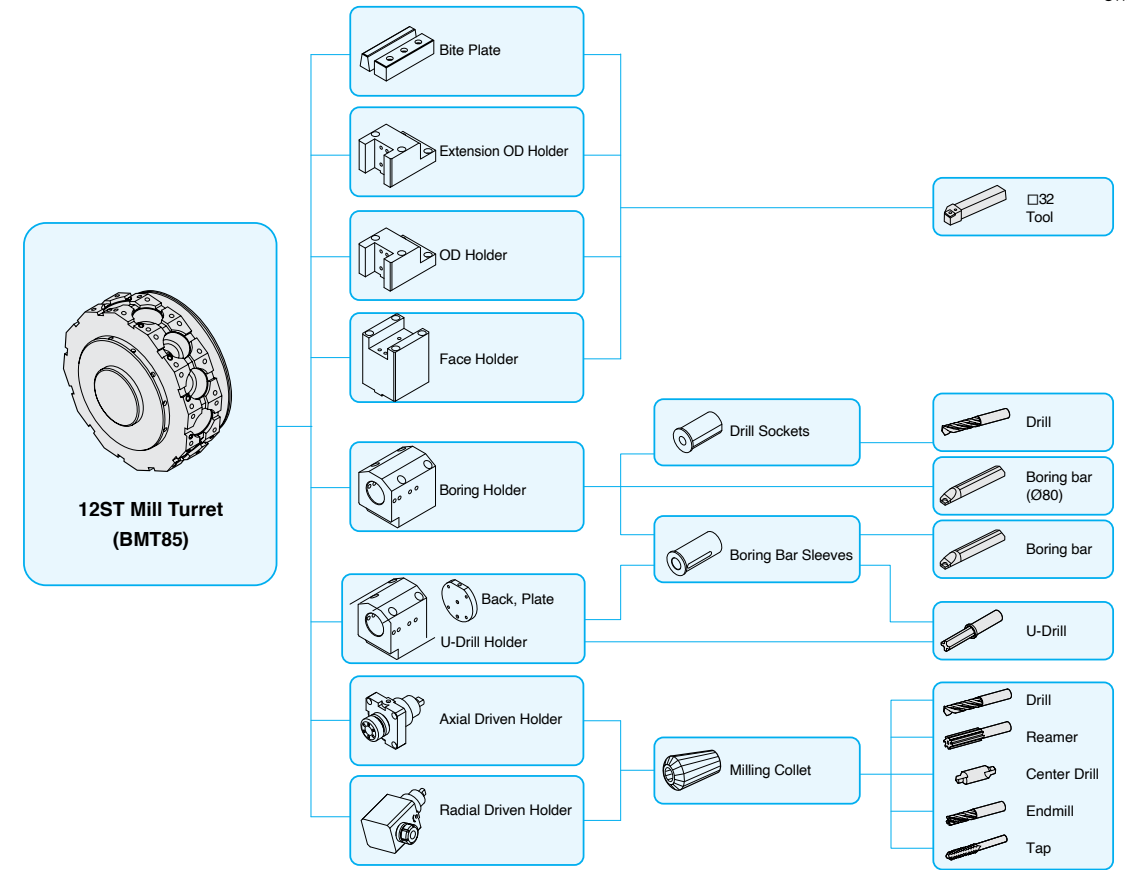

Standard Tooling

Item / Description		SL 5500M serie	SL 6500M/8500M serie
Turning Holder	EXTENSION OD HOLDER	-	1
	OD HOLDER	-	3
	Facing Holder	-	1
Boring Holder	BORING HOLDER	-	2
	U-Drill Holder	-	1
Driven Holder	AXIAL DRIVEN HOLDER	-	2
	RADIAL DRIVEN HOLDER	-	2
Socket	Boring	Ø12 (Ø1/2")	-
		Ø16 (Ø5/8")	-
		Ø20 (Ø3/4")	1
		Ø25 (Ø1")	1
		Ø32 (Ø1 1/4")	1
		Ø40 (Ø1 1/2")	1
		Ø50 (Ø2")	1
		Ø60 (Ø2 1/2")	-
	Drill	MT 2	1
		MT 3	1
		MT 4	1
		MT 5	1

Work Range

Unit : mm(inch)

SL 5500 Series

SL 5500 O.D Tool

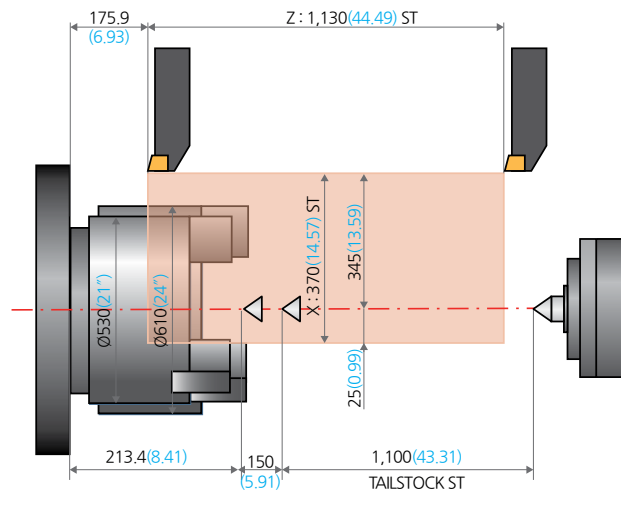

SL 5500C O.D Tool

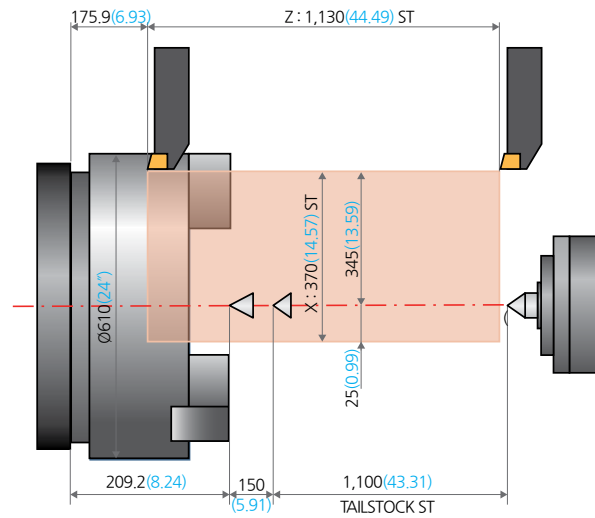

SL 5500M O.D Tool (BMT 75)

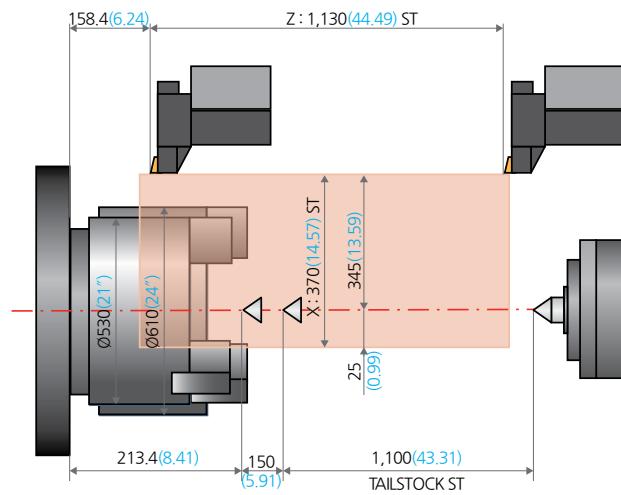

SL 5500C O.D Tool (BMT 85)

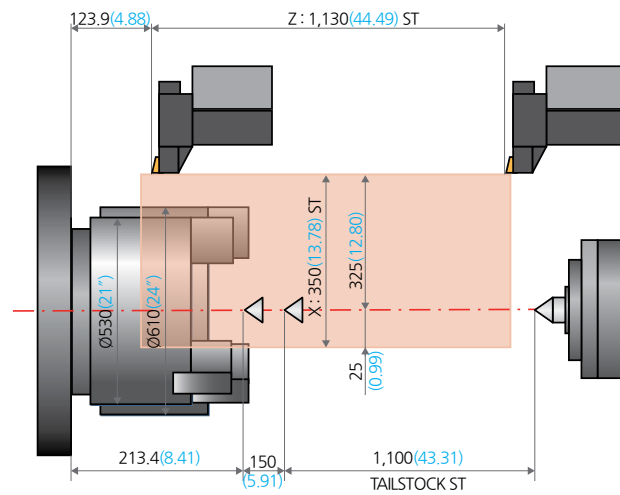

Work Range

Unit : mm(inch)

SL 6500/8500/M/XXM

O.D Tool

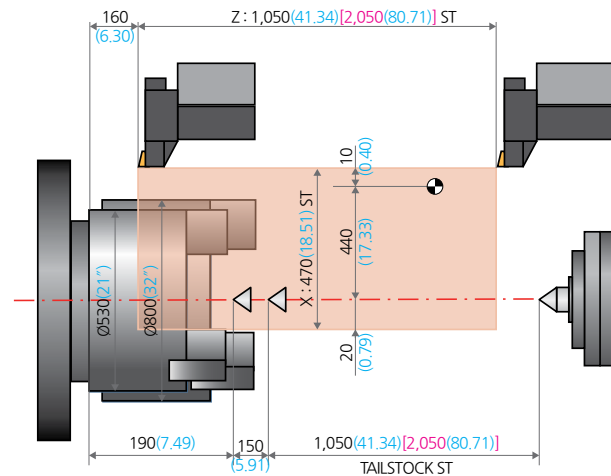

I.D Tool

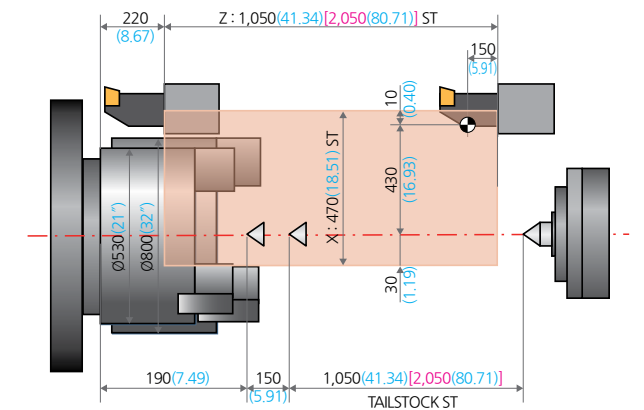

AXIAL DRIVEN CUT

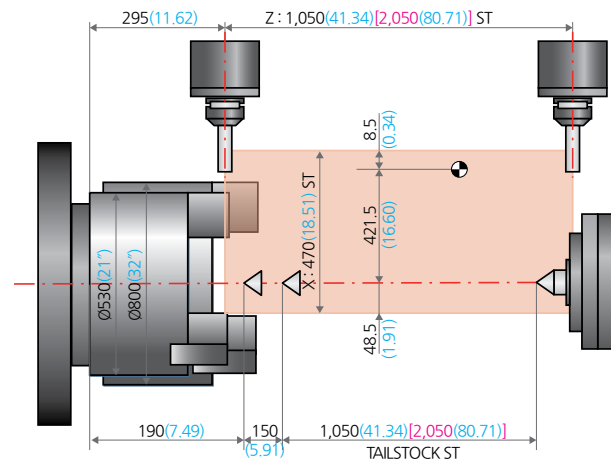

RADIAL DRIVEN CUT

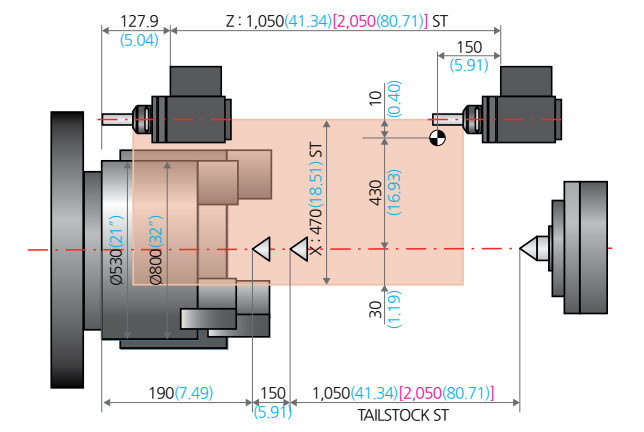

SL 5500/6500/8500 Series

HORIZONTAL TURNING CENTER

Work Range

SL 6500L/8500L/LM/XL/XLM

Unit : mm(inch)

O.D Tool

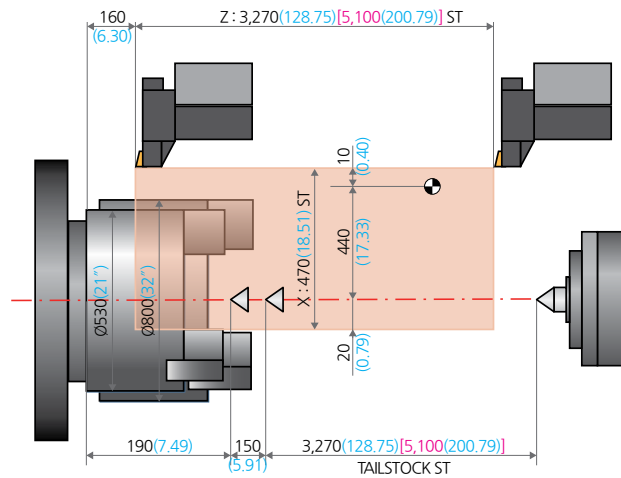

I,D Tool

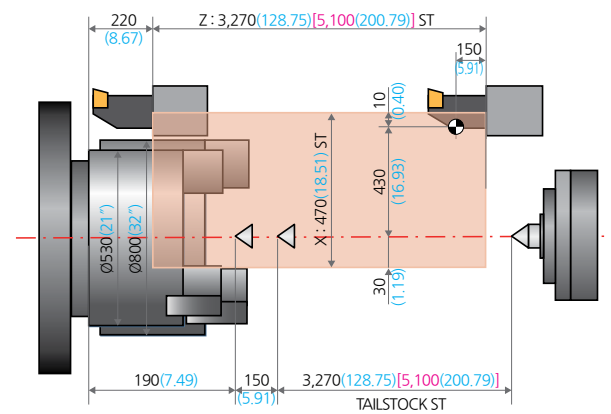

AXIAL DRIVEN CUT

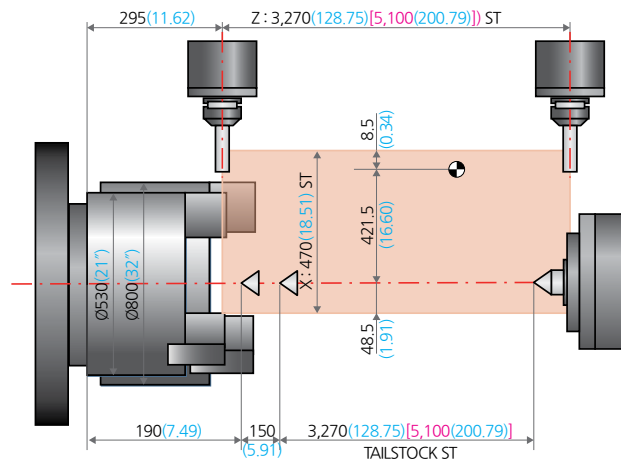

RADIAL DRIVEN CUT

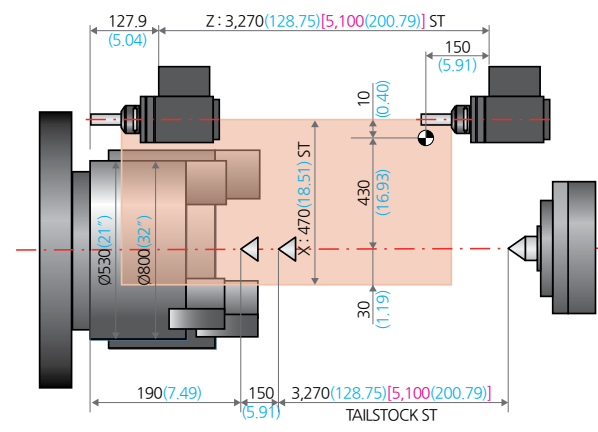

Standard / Optional

● : Standard ○ : Optional △ : To be discussed X : N/A

Category		SL 5500 SL 6500 SL 8500	SL 5500M SL 6500M SL 8500M		
Spindle	3 jaw closed-center chuck	●	●		
	Soft jaw (3set)	●	●		
	Hard jaw (1set)	○	○		
	Chuck clamp footswitch	●	●		
	Dual pressure chucking	○	○		
	C-axis control (0.001°)	X	●		
	Chuck clamp confirmation	●	●		
Turret	Tool holder	●	●		
	Rotary holder type	BMT	X	●	
	Rotary holder (Axial)	X	●		
	Rotary holder (Radial)	X	●		
	Boring bar sleeve (same as U-drill holder sleeve)	●	●		
	Drill socket	●	●		
	U-drill holder	●	●		
Tailstock	Programmable tailstock	●	●		
	Quill forward/reverse confirmation	○	○		
	Tailstock footswitch	○	○		
Coolant & Air Blow	Chuck coolant	○	○		
	Coolant gun	○	○		
	Chuck air blower	○	○		
	Rotary tool holder TSC	○	○		
	Air gun	○	○		
	Coolant pump	4.5Bar	●	●	
		7Bar	○	○	
10Bar		○	○		
14.5Bar		○	○		
20Bar		○	○		
Coolant chiller	○	○			
Chip Disposal	Chip conveyor (Hinge/ Screper)	Right-side	○	○	
		Rear	X	X	
	Special chip conveyor (Drum Filter)	△	△		
	Chip bucket	Fixed 380L	○	○	
		Rotate 275L	○	○	
	Electrical	3 step patrol lamp and buzzer		●	●
		Lamp for electrical cabinet		X	X
		Remote MPG		X	X
		Work counter	Digital	△	△
		Total counter	Digital	△	△
Tool counter		Digital	△	△	
		6EA	△	△	
Multi counter		9EA	△	△	
		Grounded circuit breaker		△	△
AVR(Auto Voltage Regulator)		X	X		
Transformer	70kVA	○	○		
Auto Power Off		○	○		
Measurement	Tool Presetter	Manual	○	○	
	Tool Presetter	Auto	○	○	
	Linear scale	X-axis	○	○	
		Z-axis	○	○	
Coolant level gauge (requires chip conveyor)		○	○		
Environmental	Air conditioner for electrical cabinet		○	○	
	Dehumidifier		△	△	
	Oil mist collector		○	○	
	Oil skimmer		○	○	
Automation	Auto door		○	○	
	Sub controller		△	△	
	Barfeeder interface		△	△	
	Additional M-codes (4 pairs)		△	△	
	Automation interface		△	△	
	I/O expansion (including both IN and OUT)	16 contacts	△	△	
		32 contacts	△	△	

※ For detailed information, please contact your local SMEC dealer.

SL 5500/6500/8500 Series

HORIZONTAL TURNING CENTER

Machine Specifications

Category		SL 5500			SL 5500M			
		A type	B type	C type	A type	B type	C type	
Chuck	Chuck Size	inch	21"	24"	32"	21"	24"	32"
Capacity	Swing over Bed	mm(inch)	900(35.44)			900(35.44)		
	Swing over Cross-slide	mm(inch)	800(31.50)			800(31.50)		
	Max. Turning Dia.	mm(inch)	690(27.17)			690(27.17)		
	Max. Turning Length	mm(inch)	1,097(43.19)	1,070(42.13)		1,079(42.49)	1,052(41.42)	
Spindle	Spindle Speed	rpm	1,500	1,000		1,200	1,000	
	Spindle Nose	ASA	A2-15	A2-20		A2-15	A2-20	
	Draw Tube I.D.	mm(inch)	166.5(6.56)	232(9.14)		166.5(6.56)	232(9.14)	
	Spindle Bore	mm(inch)	181(7.13)	275(10.83)		181(7.13)	275(10.83)	
	Spindle Motor (Cont./Max)	kW(Hp)	30/45 (40.24/60.35)	37/55 (49.62/73.76)		30/45 (40.24/60.35)	37/55 (49.62/73.76)	
Travels	X-axis Stroke	mm(inch)	370(14.57)			370(14.57)		
	Z-axis Stroke	mm(inch)	1,130(44.49)			1,130(44.49)		
	X-axis Rapid Traverse	m/min(ipm)	20(787.41)			20(787.41)		
	Z-axis Rapid Traverse	m/min(ipm)	20(787.41)			20(787.41)		
Turret	No. of Tool Positions	ea	12			12 (BMT75)		
	Shank Size for Square Tool	mm(inch)	32(1.26)			32(1.26)		
	Boring Bar Dia.	mm(inch)	80(3.15)			80(3.15)		
	Indexing Time	sec	0.25			0.25		
	Rotary Tool Speed	rpm	-			8,000		
	Rotary Tool Motor (Cont./Max)	kW(Hp)	-			7.5/11(10.06/14.76)		
Tailstock	Quill diameter	mm(inch)	160(6.30)			160(6.30)		
	Quill stroke	mm(inch)	150(5.91)			150(5.91)		
	Quill taper	MT	MT5 (Built-in)			MT5 (Built-in)		
Machine	Size <with SIDE chip conveyor> LxWxH	mm(inch)	5,159<6,041> × 2,100 × 2,344 (203.12<237.84> × 82.68 × 92.29)			5,159<6,041> × 2,100 × 2,344 (203.12<237.84> × 82.68 × 92.29)		
	Size <with REAR chip conveyor> LxWxH	mm(inch)	-			-		
	Weight	kg(lb)	15,500(34,171.66)			16,000(35,273.97)		
	Coolant tank capacity	Liter(gal)	370(97.75)			370(97.75)		
Electric power supply	kVA/V	62/220	70/220		62/220	70/220		
Controller		FANUC Oi-TF+						

* Design and specifications are subject to change without notice.

기계 사양

Category		SL 6500		SL 6500M		
		A type	B type	A type	B type	
Chuck	Chuck Size	inch	21"	24"	21"	24"
Capacity	Swing over Bed	mm(inch)	1,030(40.56)		1,030(40.56)	
	Swing over Cross-slide	mm(inch)	800(31.50)		800(31.50)	
	Max. Turning Dia.	mm(inch)	900(35.44)		900(35.44)	
	Max. Turning Length	mm(inch)	1,000(39.38)		1,000(39.38)	
Spindle	Spindle Speed	rpm	1,500	1,200	1,500	1,200
	Spindle Nose	ASA	A2-15		A2-15	
	Draw Tube I.D.	mm(inch)	140(5.52)		140(5.52)	
	Spindle Bore	mm(inch)	152(5.99)		152(5.99)	
	Spindle Motor (Cont./Max)	kW(Hp)	37/55(49.62/73.78)		37/55(49.62/73.78)	
Travels	X-axis Stroke	mm(inch)	470(18.51)		470(18.51)	
	Z-axis Stroke	mm(inch)	1,050(41.34)		1,050(41.34)	
	X-axis Rapid Traverse	m/min(ipm)	12(472.45)		12(472.45)	
	Z-axis Rapid Traverse	m/min(ipm)	18(708.67)		18(708.67)	
Turret	No. of Tool Positions	ea	12		12 (BMT85)	
	Shank Size for Square Tool	mm(inch)	32(1.26)		32(1.26)	
	Boring Bar Dia.	mm(inch)	80(3.15)		80(3.15)	
	Indexing Time	sec	0.25		0.25	
	Rotary Tool Speed	rpm	-		3,000	
	Rotary Tool Motor (Cont./Max)	kW(Hp)	-		7.5/11(10.06/14.76)	
Tailstock	Quill diameter	mm(inch)	180(7.09)		180(7.09)	
	Quill stroke	mm(inch)	150(5.91)		150(5.91)	
	Quill taper	MT	MT6 (Built-in)		MT6 (Built-in)	
Machine	Size <with SIDE chip conveyor> LxWxH	mm(inch)	5,158<6,171> × 2,714 × 2,597 (203.08<242.96> × 106.86 × 102.25)		5,158<6,171> × 2,714 × 2,597 (203.08<242.96> × 106.86 × 102.25)	
	Size <with REAR chip conveyor> LxWxH	mm(inch)	-		-	
	Weight	kg(lb)	16,500(36,376.28)		17,000(37,478.59)	
	Coolant tank capacity	Liter(gal)	400(105.67)		400(105.67)	
Electric power supply	kVA/V	70/220		70/220		
Controller		FANUC Oi-TF+				

* Design and specifications are subject to change without notice.

SL 5500/6500/8500 Series

HORIZONTAL TURNING CENTER

Machine Specifications

Category			SL 6500X		SL 6500XM	
			A type	B type	A type	B type
Chuck	Chuck Size	inch	21"	24"	21"	24"
Capacity	Swing over Bed	mm(inch)	1,030(40.56)		1,030(40.56)	
	Swing over Cross-slide	mm(inch)	800(31.50)		800(31.50)	
	Max. Turning Dia.	mm(inch)	900(35.44)		900(35.44)	
	Max. Turning Length	mm(inch)	2,000(78.75)		2,000(78.75)	
Spindle	Spindle Speed	rpm	1,500	1,200	1,500	1,200
	Spindle Nose	ASA	A2-15		A2-15	
	Draw Tube I.D.	mm(inch)	140(5.52)		140(5.52)	
	Spindle Bore	mm(inch)	152(5.99)		152(5.99)	
	Spindle Motor (Cont./Max)	kW(Hp)	37/55(49.62/73.76)		37/55(49.62/73.76)	
Travels	X-axis Stroke	mm(inch)	470(18.51)		470(18.51)	
	Z-axis Stroke	mm(inch)	2,050(80.71)		2,050(80.71)	
	X-axis Rapid Traverse	m/min(ipm)	12(472.45)		12(472.45)	
	Z-axis Rapid Traverse	m/min(ipm)	15(590.56)		15(590.56)	
Turret	No. of Tool Positions	ea	12		12 (BMT85)	
	Shank Size for Square Tool	mm(inch)	32(1.26)		32(1.26)	
	Boring Bar Dia.	mm(inch)	80(3.15)		80(3.15)	
	Indexing Time	sec	0.25		0.25	
	Rotary Tool Speed	rpm	-		3,000	
	Rotary Tool Motor (Cont./Max)	kW(Hp)	-		7.5/11(10.06/14.76)	
Tailstock	Quill diameter	mm(inch)	180(7.09)		180(7.09)	
	Quill stroke	mm(inch)	150(5.91)		150(5.91)	
	Quill taper	MT	MT6 (Built-in)		MT6 (Built-in)	
Machine	Size <with SIDE chip conveyor> LxWxH	mm(inch)	6,203<7,216> × 2,910 × 2,520 (244.22<284.10> × 114.57 × 99.22)		6,203<7,216> × 2,910 × 2,520 (244.22<284.10> × 114.57 × 99.22)	
	Size <with REAR chip conveyor> LxWxH	mm(inch)	-		-	
	Weight	kg(lb)	19,000(41,887.83)		19,500(42,990.15)	
	Coolant tank capacity	Liter(gal)	500(132.09)		500(132.09)	
Electric power supply	kVA/V	70/220		70/220		
Controller	FANUC Oi-TF+					

* Design and specifications are subject to change without notice.

Machine Specifications

Category			SL 6500L		SL 6500LM	
			A type	B type	A type	B type
Chuck	Chuck Size	inch	21"	24"	21"	24"
Capacity	Swing over Bed	mm(inch)	1,030(40.56)		1,030(40.56)	
	Swing over Cross-slide	mm(inch)	800(31.50)		800(31.50)	
	Max. Turning Dia.	mm(inch)	900(35.44)		900(35.44)	
	Max. Turning Length	mm(inch)	3,200(125.99)		3,200(125.99)	
Spindle	Spindle Speed	rpm	1,500	1,200	1,500	1,200
	Spindle Nose	ASA	A2-15		A2-15	
	Draw Tube I.D.	mm(inch)	140(5.52)		140(5.52)	
	Spindle Bore	mm(inch)	152(5.99)		152(5.99)	
	Spindle Motor (Cont./Max)	kW(Hp)	37/55(49.62/73.76)		37/55(49.62/73.76)	
Travels	X-axis Stroke	mm(inch)	470(18.51)		470(18.51)	
	Z-axis Stroke	mm(inch)	3,270(128.75)		3,270(128.75)	
	X-axis Rapid Traverse	m/min(ipm)	12(472.45)		12(472.45)	
	Z-axis Rapid Traverse	m/min(ipm)	10(393.71)		10(393.71)	
Turret	No. of Tool Positions	ea	12		12 (BMT85)	
	Shank Size for Square Tool	mm(inch)	32(1.26)		32(1.26)	
	Boring Bar Dia.	mm(inch)	80(3.15)		80(3.15)	
	Indexing Time	sec	0.25		0.25	
	Rotary Tool Speed	rpm	-		3,000	
	Rotary Tool Motor (Cont./Max)	kW(Hp)	-		7.5/11(10.06/14.76)	
Tailstock	Quill diameter	mm(inch)	180(7.09)		180(7.09)	
	Quill stroke	mm(inch)	150(5.91)		150(5.91)	
	Quill taper	MT	MT6 (Built-in)		MT6 (Built-in)	
Machine	Size <with SIDE chip conveyor> LxWxH	mm(inch)	7,400<8,413> × 2,910 × 2,595 (291.34<331.23> × 114.57 × 102.17)		7,400<8,413> × 2,910 × 2,595 (291.34<331.23> × 114.57 × 102.17)	
	Size <with REAR chip conveyor> LxWxH	mm(inch)	-		-	
	Weight	kg(lb)	22,000(48,501.70)		22,500(49,604.01)	
	Coolant tank capacity	Liter(gal)	600(158.51)		600(158.51)	
Electric power supply	kVA/V	70/220		70/220		
Controller	FANUC Oi-TF+					

* Design and specifications are subject to change without notice.

SL 5500/6500/8500 Series

HORIZONTAL TURNING CENTER

Machine Specifications

Category			SL 6500XL		SL 6500XLM	
			A type	B type	A type	B type
Chuck	Chuck Size	inch	21"	24"	21"	24"
Capacity	Swing over Bed	mm(inch)	1,030(40.56)		1,030(40.56)	
	Swing over Cross-slide	mm(inch)	800(31.50)		800(31.50)	
	Max. Turning Dia.	mm(inch)	900(35.44)		900(35.44)	
	Max. Turning Length	mm(inch)	5,050(198.82)		5,050(198.82)	
Spindle	Spindle Speed	rpm	1,500	1,200	1,500	1,200
	Spindle Nose	ASA	A2-15		A2-15	
	Draw Tube I.D.	mm(inch)	140(5.52)		140(5.52)	
	Spindle Bore	mm(inch)	152(5.99)		152(5.99)	
	Spindle Motor (Cont./Max)	kW(Hp)	37/55(49.62/73.76)		37/55(49.62/73.76)	
Travels	X-axis Stroke	mm(inch)	470(18.51)		470(18.51)	
	Z-axis Stroke	mm(inch)	5,100(200.79)		5,100(200.79)	
	X-axis Rapid Traverse	m/min(ipm)	12(472.45)		12(472.45)	
	Z-axis Rapid Traverse	m/min(ipm)	10(393.71)		10(393.71)	
Turret	No. of Tool Positions	ea	12		12 (BMT85)	
	Shank Size for Square Tool	mm(inch)	32(1.26)		32(1.26)	
	Boring Bar Dia.	mm(inch)	80(3.15)		80(3.15)	
	Indexing Time	sec	0.25		0.25	
	Rotary Tool Speed	rpm	-		3,000	
	Rotary Tool Motor (Cont./Max)	kW(Hp)	-		7.5/11(10.06/14.76)	
Tailstock	Quill diameter	mm(inch)	180(7.09)		180(7.09)	
	Quill stroke	mm(inch)	150(5.91)		150(5.91)	
	Quill taper	MT	MT6 (Built-in)		MT6 (Built-in)	
Machine	Size <with SIDE chip conveyor> LxWxH	mm(inch)	9,281<10,351> × 2,980 × 2,555 (365.40<407.52> × 117.33 × 100.60)		9,281<10,351> × 2,980 × 2,555 (365.40<407.52> × 117.33 × 100.60)	
	Size <with REAR chip conveyor> LxWxH	mm(inch)	-		-	
	Weight	kg(lb)	26,000(57,320.19)		26,500(58,422.50)	
	Coolant tank capacity	Liter(gal)	790(208.70)		790(208.70)	
Electric power supply	kVA/V	70/220		70/220		
Controller	FANUC Oi-TF+					

※ Design and specifications are subject to change without notice.

Machine Specifications

Category			SL 8500		SL 8500M	
			A type	B type	A type	B type
Chuck	Chuck Size	inch	32"	32"	32"	32"
Capacity	Swing over Bed	mm(inch)	1,030(40.56)		1,030(40.56)	
	Swing over Cross-slide	mm(inch)	800(31.50)		800(31.50)	
	Max. Turning Dia.	mm(inch)	900(35.44)		900(35.44)	
	Max. Turning Length	mm(inch)	1,000(39.38)		1,000(39.38)	
Spindle	Spindle Speed	rpm	500	300	500	300
	Spindle Nose	ASA	A1-20	A2-20	A1-20	A2-20
	Draw Tube I.D.	mm(inch)	232(9.14)		232(9.14)	
	Spindle Bore	mm(inch)	321(12.64)	365(14.38)	321(12.64)	365(14.38)
	Spindle Motor (Cont./Max)	kW(Hp)	37/55(49.62/73.76)		37/55(49.62/73.76)	
Travels	X-axis Stroke	mm(inch)	470(18.51)		470(18.51)	
	Z-axis Stroke	mm(inch)	1,050(41.34)		1,050(41.34)	
	X-axis Rapid Traverse	m/min(ipm)	12(472.45)		12(472.45)	
	Z-axis Rapid Traverse	m/min(ipm)	10(393.71)		10(393.71)	
Turret	No. of Tool Positions	ea	12		12 (BMT85)	
	Shank Size for Square Tool	mm(inch)	32(1.26)		32(1.26)	
	Boring Bar Dia.	mm(inch)	80(3.15)		80(3.15)	
	Indexing Time	sec	0.25		0.25	
	Rotary Tool Speed	rpm	-		8,000	
	Rotary Tool Motor (Cont./Max)	kW(Hp)	-		7.5/11(10.06/14.76)	
Tailstock	Quill diameter	mm(inch)	180(7.09)		180(7.09)	
	Quill stroke	mm(inch)	150(5.91)		150(5.91)	
	Quill taper	MT	MT6 (Built-in)		MT6 (Built-in)	
Machine	Size <with SIDE chip conveyor> LxWxH	mm(inch)	5,158<6,171> × 2,714 × 2,597 (203.08<242.96> × 106.86 × 102.25)		5,158<6,171> × 2,714 × 2,597 (203.08<242.96> × 106.86 × 102.25)	
	Size <with REAR chip conveyor> LxWxH	mm(inch)	-		-	
	Weight	kg(lb)	16,500(36,376.28)		17,000(37,478.59)	
	Coolant tank capacity	Liter(gal)	400(105.67)		400(105.67)	
Electric power supply	kVA/V	70/220		70/220		
Controller	FANUC Oi-TF+					

※ Design and specifications are subject to change without notice.

SL 5500/6500/8500 Series

HORIZONTAL TURNING CENTER

Machine Specifications

Category		SL 8500X		SL 8500XM		
		A type	B type	A type	B type	
Chuck	Chuck Size	inch	32"	32"	32"	32"
Capacity	Swing over Bed	mm(inch)	1,030(40.56)		1,030(40.56)	
	Swing over Cross-slide	mm(inch)	800(31.50)		800(31.50)	
	Max. Turning Dia.	mm(inch)	900(35.44)		900(35.44)	
	Max. Turning Length	mm(inch)	2,000(78.75)		2,000(78.75)	
Spindle	Spindle Speed	rpm	500	300	500	300
	Spindle Nose	ASA	A1-20	A2-20	A1-20	A2-20
	Draw Tube I.D.	mm(inch)	232(9.14)		232(9.14)	
	Spindle Bore	mm(inch)	321(12.64)	365(14.38)	321(12.64)	365(14.38)
	Spindle Motor (Cont./Max)	kW(Hp)	37/55(49.62/73.76)		37/55(49.62/73.76)	
Travels	X-axis Stroke	mm(inch)	470(18.51)		470(18.51)	
	Z-axis Stroke	mm(inch)	2,050(80.71)		2,050(80.71)	
	X-axis Rapid Traverse	m/min(ipm)	12(472.45)		12(472.45)	
	Z-axis Rapid Traverse	m/min(ipm)	15(590.56)		15(590.56)	
Turret	No. of Tool Positions	ea	12		12 (BMT85)	
	Shank Size for Square Tool	mm(inch)	32(1.26)		32(1.26)	
	Boring Bar Dia.	mm(inch)	80(3.15)		80(3.15)	
	Indexing Time	sec	0.25		0.25	
	Rotary Tool Speed	rpm	-		8,000	
	Rotary Tool Motor (Cont./Max)	kW(Hp)	-		7.5/11(10.06/14.76)	
Tailstock	Quill diameter	mm(inch)	180(7.09)		180(7.09)	
	Quill stroke	mm(inch)	150(5.91)		150(5.91)	
	Quill taper	MT	MT6 (Built-in)		MT6 (Built-in)	
Machine	Size <with SIDE chip conveyor> LxWxH	mm(inch)	6,203<7,216> × 2,910 × 2,520 (244.22<284.10> × 114.57 × 99.22)		6,203<7,216> × 2,910 × 2,520 (244.22<284.10> × 114.57 × 99.22)	
	Size <with REAR chip conveyor> LxWxH	mm(inch)	-		-	
	Weight	kg(lb)	19,000(41,887.83)		19,500(42,990.15)	
	Coolant tank capacity	Liter(gal)	500(132.09)		500(132.09)	
Electric power supply		kVA/V	70/220		70/220	
Controller		FANUC Oi-TF+				

※ Design and specifications are subject to change without notice.

Machine Specifications

[] : Optional

Category		SL 8500L		SL 8500LM		
		A type	B type	A type	B type	
Chuck	Chuck Size	inch	32"	32"	32"	32"
Capacity	Swing over Bed	mm(inch)	1,030(40.56)		1,030(40.56)	
	Swing over Cross-slide	mm(inch)	800(31.50)		800(31.50)	
	Max. Turning Dia.	mm(inch)	900(35.44)		900(35.44)	
	Max. Turning Length	mm(inch)	3,200(125.99)		3,200(125.99)	
Spindle	Spindle Speed	rpm	500	300	500	300
	Spindle Nose	ASA	A1-20	A2-20	A1-20	A2-20
	Draw Tube I.D.	mm(inch)	232(9.14)		232(9.14)	
	Spindle Bore	mm(inch)	321(12.64)	365(14.38)	321(12.64)	365(14.38)
	Spindle Motor (Cont./Max)	kW(Hp)	37/55(49.62/73.76)		37/55(49.62/73.76)	
Travels	X-axis Stroke	mm(inch)	470(18.51)		470(18.51)	
	Z-axis Stroke	mm(inch)	3,270(128.75)		3,270(128.75)	
	X-axis Rapid Traverse	m/min(ipm)	12(472.45)		12(472.45)	
	Z-axis Rapid Traverse	m/min(ipm)	10(393.71)		10(393.71)	
Turret	No. of Tool Positions	ea	12		12 (BMT85)	
	Shank Size for Square Tool	mm(inch)	32(1.26)		32(1.26)	
	Boring Bar Dia.	mm(inch)	80(3.15)		80(3.15)	
	Indexing Time	sec	0.25		0.25	
	Rotary Tool Speed	rpm	-		8,000	
	Rotary Tool Motor (Cont./Max)	kW(Hp)	-		7.5/11(10.06/14.76)	
Tailstock	Quill diameter	mm(inch)	180(7.09)		180(7.09)	
	Quill stroke	mm(inch)	150(5.91)		150(5.91)	
	Quill taper	MT	MT6 (Built-in)		MT6 (Built-in)	
Machine	Size <with SIDE chip conveyor> LxWxH	mm(inch)	7,400<8,413> × 2,910 × 2,595 (291.34<331.23> × 114.57 × 102.17)		7,400<8,413> × 2,910 × 2,595 (291.34<331.23> × 114.57 × 102.17)	
	Size <with REAR chip conveyor> LxWxH	mm(inch)	-		-	
	Weight	kg(lb)	22,000(48,501.70)		22,500(49,604.01)	
	Coolant tank capacity	Liter(gal)	600(158.51)		600(158.51)	
Electric power supply		kVA/V	70/220		70/220	
Controller		FANUC Oi-TF+				

※ Design and specifications are subject to change without notice.

SL 5500/6500/8500 Series

HORIZONTAL TURNING CENTER

Machine Specifications

[] : Optional

Category		SL 8500XL		SL 8500XLM		
		A type	B type	A type	B type	
Chuck	Chuck Size	inch	32"	32"	32"	32"
Capacity	Swing over Bed	mm(inch)	1,030(40.56)		1,030(40.56)	
	Swing over Cross-slide	mm(inch)	800(31.50)		800(31.50)	
	Max. Turning Dia.	mm(inch)	900(35.44)		900(35.44)	
	Max. Turning Length	mm(inch)	5,050(198.82)		5,050(198.82)	
Spindle	Spindle Speed	rpm	500	300	500	300
	Spindle Nose	ASA	A1-20	A2-20	A1-20	A2-20
	Draw Tube I.D.	mm(inch)	232(9.14)		232(9.14)	
	Spindle Bore	mm(inch)	321(12.64)	365(14.38)	321(12.64)	365(14.38)
	Spindle Motor (Cont./Max)	kW(Hp)	37/55(49.62/73.76)		37/55(49.62/73.76)	
Travels	X-axis Stroke	mm(inch)	470(18.51)		470(18.51)	
	Z-axis Stroke	mm(inch)	5,100(200.79)		5,100(200.79)	
	X-axis Rapid Traverse	m/min(ipm)	12(472.45)		12(472.45)	
	Z-axis Rapid Traverse	m/min(ipm)	10(393.71)		10(393.71)	
Turret	No. of Tool Positions	ea	12		12 (BMT85)	
	Shank Size for Square Tool	mm(inch)	32(1.26)		32(1.26)	
	Boring Bar Dia.	mm(inch)	80(3.15)		80(3.15)	
	Indexing Time	sec	0.25		0.25	
	Rotary Tool Speed	rpm	-		8,000	
	Rotary Tool Motor (Cont./Max)	kW(Hp)	-		7.5/11(10.06/14.76)	
Tailstock	Quill diameter	mm(inch)	180(7.09)		180(7.09)	
	Quill stroke	mm(inch)	150(5.91)		150(5.91)	
	Quill taper	MT	MT6 (Built-in)		MT6 (Built-in)	
Machine	Size (with SIDE chip conveyor) LxWxH	mm(inch)	9,281<10,351> × 2,980 × 2,555 (365.40<407.52> × 117.33 × 100.60)		9,281<10,351> × 2,980 × 2,555 (365.40<407.52> × 117.33 × 100.60)	
	Size (with REAR chip conveyor) LxWxH	mm(inch)	-		-	
	Weight	kg(lb)	26,000(57,320.19)		26,500(58,422.50)	
	Coolant tank capacity	Liter(gal)	790(208.70)		790(208.70)	
Electric power supply	kVA/V	70/220		70/220		
Controller		FANUC Oi-TF+				

* Design and specifications are subject to change without notice.

NC Specification / FANUC

● : Standard ○ : Optional () : Option X : N/A

Category		Oi-TF+	Category	Oi-TF+	
Controlled axis	Controlled axes	X, Z	Absolute/incremental programming	G90/G91	
	Max. simultaneously controlled axes	4	Multiple repetitive cycle	●	
	Least command increment	0.001mm / 0.0001"	Multiple repetitive cycle II	●	
	Stored stroke check	Soft overtravel 1, 2, 3	Canned cycles	●	
	Machine lock	●	Canned cycle for drilling	●	
Operation functions	Pulse handle feed	X1, X10, X100	Decimal point programming	●	
	Dry run	●	Inch/metric conversion	G20 / G21	
	Single block	●	Program restart	●	
	Feedrate per minute	G94	Sub program call	●	
	Feedrate per revolution	G95	Max. programmable dimension	±99999.999mm/±9999.9999"	
	DNC operation	Ethernet, CF card	M function	3 digit	
Interpolation functions	Retraction for rigid tapping	○	Custom macro	●	
	Linear interpolation	G01	Addition of custom macro common variables	#100~#199, #500~#999	
	Circular interpolation	G02, G03	Direct drawing dimension programming	●	
	Dwell	G04	Programmable data input	G10	
	Cylindrical interpolation	G70.1	Tape code	ISO / EIA	
	Skip	G31	Optional block skip	●	
	Nano smoothing	X	Workpiece coordinate system	G52 ~ G59	
	Polar coordinate interpolation	●	Addition of workpiece coordinate system	X	
	Reference position return	G28	Interface function	Embedded ethernet	●
	Reference position return check	G27		Fast ethernet	X
	2nd/3rd/4th reference position return	G30	Setting and display	Alarm & Operator histor display	●
	Variable lead thread cutting	●		Run hour and parts count display	●
	Thread Repair	●		Display spindle & servo overload	●
	Rapid traverse rate override	F0, 25%, 50%, 100%		Self-diagnosis function	●
Feedrate override	0~200%	Extended part program editing		●	
Jog Override	●	Machining condition selecting function		○	
AI advanced preview control	X	Machining quality level adjustment	X		
AI contour control II	○ (200 block)	Display screen	15" color LCD		
Spindle function	Spindle orientation	●	Multi-language display	25 language	
	Rigid tapping	M29	Data input/output	Fast data server	X
	Spindle override	S0 ~ 150%		RS232C interface	●
Arbitrary speed threading	○	Memory card input/output		●	
Tool functions	Tool number command	T4-Digit Tool number	USB memory input/output	●	
	Tool nose radius compensation	G40 ~ G42	Editing operation	Part program storage size	512Kbyte(2Mbyte)
	Tool offset pairs	128-pairs		Number of registerable programs	400(1,000) EA
	Tool geometry/wear offset	●		Manual guide Oi	○
	Tool length offset	●		Manual guide i	●
	Tool life management	●			
Tool path graphic display	●				